

## Series F Carbon Steel

- Gear Operated Ball Valve
- ANSI Class 150 (285 PSI WP)
- 6" Through 10"
- Bolted Body Construction
  - Exclusive Balon Gearbox
    - ✓ Suitable for Buried Service
    - ✓ Stainless Steel Input Shaft Standard
    - ✓ Stainless Steel Directional Indicator
    - ✓ Integral Locking Device Standard
    - ✓ Manufactured in our Oklahoma City Plant
  - Multi-Seal Seats
  - Fire Safe Design
  - NACE Option with 316 Stainless Steel Ball and Stem Available
  - Maintenance Free

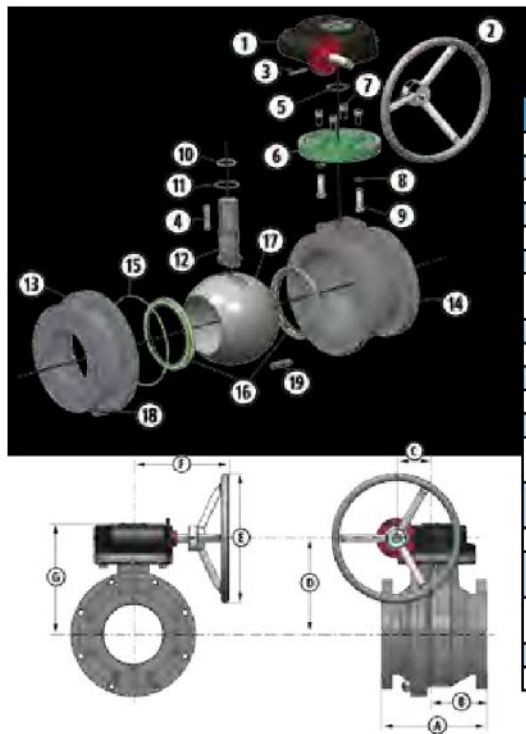

### Material Description

ITEM	PART NAME	MATERIAL (STANDARD)	MATERIAL (NACE)	LOW TEMP (NACE)
1	Gear Operator	Ductile Iron	Ductile Iron	Ductile Iron
2	Hand Wheel	Carbon Steel	Carbon Steel	Carbon Steel
3	Drive Pin	Carbon Spring Steel	Carbon Spring Steel	Carbon Spring Steel
4	Stem Key	Steel Key Stock	Steel Key Stock	Steel Key Stock
5	Stem Retainer Ring	Carbon Spring Steel	Carbon Spring Steel	Carbon Spring Steel
6	Mounting Plate	Ductile Iron	Ductile Iron	Ductile Iron
7	Mounting Plate Screws	Alloy Steel	Alloy Steel	Alloy Steel
8	Lock Washers	Carbon Steel	Carbon Steel	Carbon Steel
9	Mounting Screws	Alloy Steel	Alloy Steel	Alloy Steel
10	Stem O-Ring	Buna-N	Fluorocarbon	Fluorocarbon
11	Stem Seal	TFE	TFE	TFE
12	Stem	Carbon Steel	316 Stainless Steel	316 Stainless Steel
13	End Adapter	ASTM A216 WCB/A105	ASTM A216 WCB/A105	ASTM A352 LCC/A350 LF2
14	Body	ASTMA216 WCB/A105	ASTMA216 WCB/A105	ASTM A352 LCC/A350 LF2
15	Body O-Ring	Buna-N	Fluorocarbon	Fluorocarbon
16	Ball Seats	Nylon (TFE Optional)	Nylon (TFE Optional)	Nylon (TFE Optional)
17	Ball	Carbon Steel Nickel Chrome Plated	316 Stainless Steel	316 Stainless Steel
18	Nuts	ASTM A194 2H	ASTM A194 2HM	ASTM A320 7M
19	Body Bolts	ASTM A193 B7	ASTMA193 B7M	ASTM A320 L7M

### Dimensional Data

SIZE	CATALOG NUMBER			PORT	A	B	C	D	E	F	G	LBS.	Cv
	STANDARD TRIM CARBON STEEL BALL & STEM	NACE TRIM 316 SS BALL & STEM	LOW TEMP 316 SS BALL & STEM										
6x6x6	6F-F13-RF	6F-F13N-RF	6F-F13NL-RF	6	10.5	4.50	4	9.75	13	9	11.19	230	-
6x6x6	6F-F13-RF15.5	6F-F13N-RF15.5	N/A	6	15.5	4.50	4	9.75	13	9	11.19	255	-
8x8x8	8R-F13-RF	8R-F13N-RF	N/A	6	11.5	5.12	4	9.75	13	9	11.19	285	2200
8x8x8	8F-F13-RF	8F-F13N-RF	8F-F13NL-RF	8	16	5	5.25	12	20	11.5	13.75	520	-
10x8x10	10R-F13-RF	10R-F13N-RF	N/A	8	21	9	5.25	12	20	11.5	13.75	580	4200

# Series F Carbon Steel

- Gear Operated Ball Valve
- ANSI Class 300 (740 PSI WP)
- 6" Through 8"
- Bolted Body Construction
  - Exclusive Balon Gearbox
    - ✓ Suitable for Buried Service
    - ✓ Stainless Steel Input Shaft Standard
    - ✓ Stainless Steel Directional Indicator
    - ✓ Integral Locking Device Standard
    - ✓ Manufactured in our Oklahoma City Plant
  - Multi-Seal Seats
  - Fire Safe Design
  - NACE Option With 316 Stainless Steel Ball and Stem Available
  - Maintenance Free

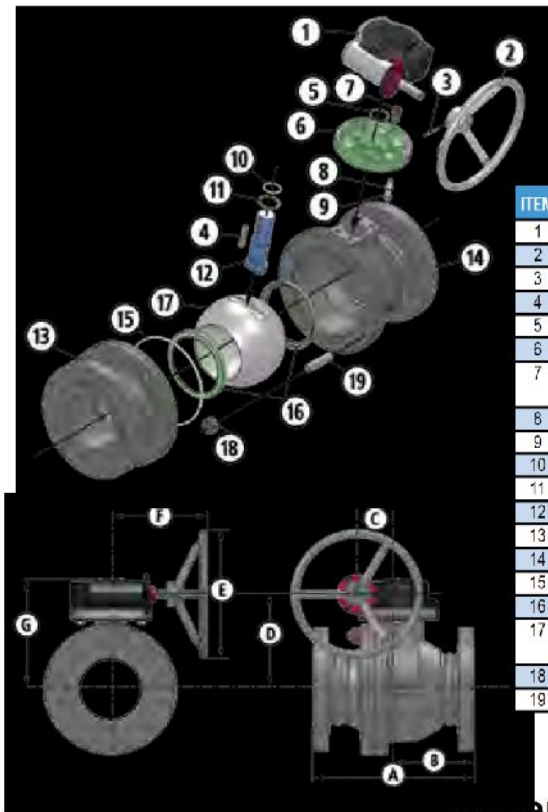

## Material Description

ITEM	PART NAME	MATERIAL (STANDARD)	MATERIAL (NACE)	LOW TEMP (NACE)
1	Gear Operator	Ductile Iron	Ductile Iron	Ductile Iron
2	Hand Wheel	Carbon Steel	Carbon Steel	Carbon Steel
3	Drive Pin	Carbon Spring Steel	Carbon Spring Steel	Carbon Spring Steel
4	Stem Key	Steel Key Stock	Steel Key Stock	Steel Key Stock
5	Stem Retainer Ring	Carbon Spring Steel	Carbon Spring Steel	Carbon Spring Steel
6	Mounting Plate	Ductile Iron	Ductile Iron	Ductile Iron
7	Mounting Plate Screws	Alloy Steel	Alloy Steel	Alloy Steel
8	Lock Washers	Carbon Steel	Carbon Steel	Carbon Steel
9	Mounting Screws	Alloy Steel	Alloy Steel	Alloy Steel
10	Stem O-Ring	Buna-N	Fluorocarbon	Fluorocarbon
11	Stem Seal	TFE	TFE	TFE
12	Stem	Carbon Steel	316 Stainless Steel	316 Stainless Steel
13	End Adapter	ASTM A216 WCB/A105	ASTM A216 WCB/A105	ASTM A352 LCC/A350 LF2
14	Body	ASTM A216 WCB/A105	ASTM A216 WCB/A105	ASTM A352 LCC/A350 LF2
15	Body O-Ring	Buna-N	Fluorocarbon	Fluorocarbon
16	Ball Seats	Nylon (TFE Optional)	Nylon (TFE Optional)	Nylon (TFE Optional)
17	Ball	Carbon Steel Nickel Chrome Plated	316 Stainless Steel	316 Stainless Steel
18	Nuts	ASTM A194 2H	ASTM A194 2HM	ASTM A320 7M
19	Body Bolts	ASTM A193 B7	ASTM A193 B7M	ASTM A320 L7M

## Dimensional Data

SIZE	CATALOG NUMBER			PORT	A	B	C	D	E	F	G	LBS.	Cv
	STANDARD TRIM CARBON STEEL BALL & STEM	NACE TRIM 316 SS BALL & STEM	LOW TEMP 316 SS BALL & STEM										
6x6x6	6F-F33-RF	6F-F33N-RF	6F-F33NL-RF	6	15.87	7.38	4	9.75	13	9	11.19	307	-
8x6x8	8R-F33-RF	8R-F33N-RF	N/A	6	18.50	7.69	4	9.75	13	9	11.19	409	2200



## Series F Carbon Steel

- Gear Operated Ball Valve
- ANSI Class 600 (1480 PSI WP)
- 4" Through 8"
- Bolted Body Construction
  - Exclusive Balon Gearbox
    - ✓ Suitable for Buried Service
    - ✓ Stainless Steel Input Shaft Standard
    - ✓ Stainless Steel Directional Indicator
    - ✓ Integral Locking Device Standard
    - ✓ Manufactured in our Oklahoma City Plant
  - Multi-Seal Seats
  - Fire Safe Design
  - NACE Option with 316 Stainless Steel Ball and Stem Available
  - Maintenance Free



### Material Description

ITEM	PART NAME	MATERIAL (STANDARD)	MATERIAL (NACE)	LOW TEMP (NACE)
1	Gear Operator	Ductile Iron	Ductile Iron	Ductile Iron
2	Hand Wheel	Carbon Steel	Carbon Steel	Carbon Steel
3	Drive Pin	Carbon Spring Steel	Carbon Spring Steel	Carbon Spring Steel
4	Stem Key	Steel Key Stock	Steel Key Stock	Steel Key Stock
5	Stem Retainer Ring	Carbon Spring Steel	Carbon Spring Steel	Carbon Spring Steel
6	Mounting Plate	Ductile Iron	Ductile Iron	Ductile Iron
7	Mounting Plate Screws	Alloy Steel	Alloy Steel	Alloy Steel
8	Lock Washers	Carbon Steel	Carbon Steel	Carbon Steel
9	Mounting Screws	Alloy Steel	Alloy Steel	Alloy Steel
10	Stem O-Ring	Buna-N	Fluorocarbon	Fluorocarbon
11	Stem Seal	TFE	TFE	TFE
12	Stem	Carbon Steel	316 Stainless Steel	316 Stainless Steel
13	End Adapter	ASTMA216 WCB/A105	ASTMA216 WCB/A105	ASTMA352 LCC/A350 LF2
14	Body	ASTMA216 WCB/A105	ASTMA216 WCB/A105	ASTMA352 LCC/A350 LF2
15	Body O-Ring	Buna-N	Fluorocarbon	Fluorocarbon
16	Ball Seats	Nylon (TFE Optional)	Nylon (TFE Optional)	Nylon (TFE Optional)
17	Ball	Carbon Steel Nickel Chrome Plated	316 Stainless Steel	316 Stainless Steel
18	Nuts	ASTM A194 2H	ASTM A194 2HM	ASTM A320 7M
19	Body Bolts	ASTM A193 B7	ASTM A193 B7M	ASTM A320 L7M

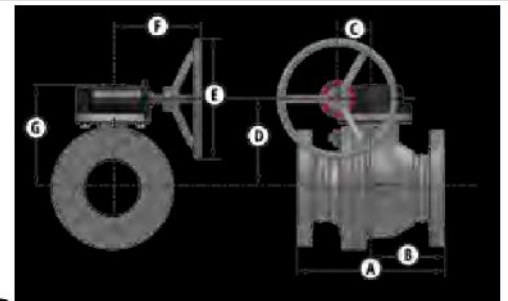
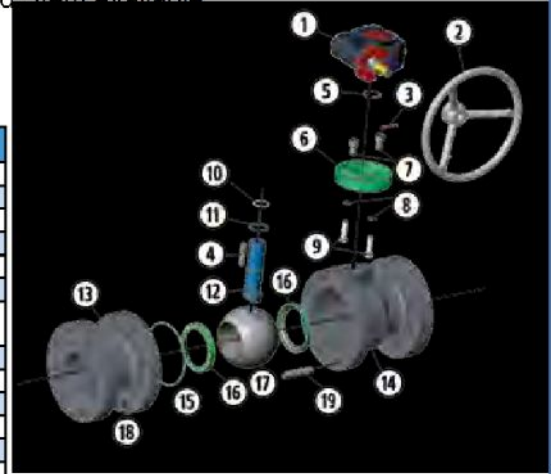

### Dimensional Data

SIZE	CATALOG NUMBER			PORT	A		B		C	D	E	F	G	LBS.	Cv
	STANDARD TRIM CARBON STEEL BALL & STEM	NACE TRIM 316 SS BALL & STEM	LOW TEMP 316SS BALL & STEM		RF	RTJ	RF	RTJ							
	4x4x4	4F-F63	4F-F63N		4F-F63NL-RF	4	17	17.12							
6x4x6	6R-F63	6R-F63N	6R-F63NL-RF	4	22	22.12	9.88	9.25	3	8.19	13	9	9.69	340	800
6x6x6	6F-F63	6F-F63N	6F-F63NL-RF	6	22	22.12	8.62	8.68	4	9.75	20	11	11.19	440	-
8x6x8	8R-F63	8R-F63N	8R-F63NL-RF	6	26	26.12	10.62	10.66	4	9.75	20	11	11.19	570	2200