

## Series F Carbon Steel

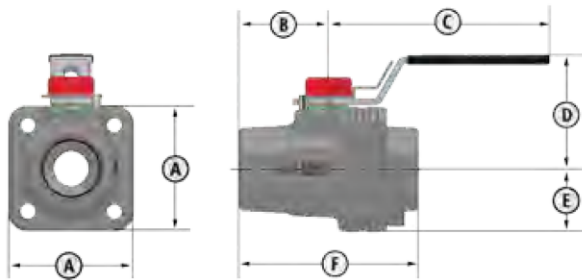
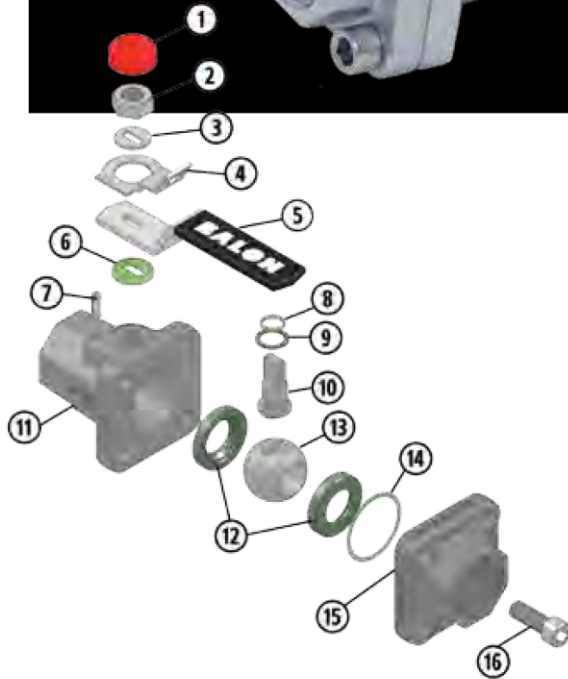

- Lever Operated Ball Valve
- 3000 PSI WP
- 1/4" Through 1"
- Bolted Body Construction

- Forged Body and Adapter
- Rugged Bolted Construction
- NACE Standard
- Low-Torque Operation
- Multi-Seal Seats
- Maintenance Free
- Fire Safe Design

### Material Description

ITEM	PART NAME	MATERIAL (NACE)
1	Weather Guard	Polyethylene
2	Stem Nut	Carbon Steel
3	Spacer	Carbon Steel
4	Lock Plate	Carbon Steel
5	Handle	Carbon Steel
6	Stem Washer	Acetal
7	Stop Pin	Carbon Steel
8	Stem O-Ring	Fluorocarbon
9	Stem Seal	TFE
10	Stem	316 Stainless Steel
11	Body	ASTM A105/A350 LF2
12	Seat	Nylon (TFE Optional)
13	Ball	316 Stainless Steel
14	Body Seal	Fluorocarbon
15	End Adapter	ASTM A105/A350 LF2
16	Body Bolts	ASTM A193 B7M/ A320 L7M

\* Handle and lock device are standard.

### Dimensional Data

SIZE	CATALOG NUMBER		PORT	WP	A	B	C	D	E	F	LBS.	Cv
	NACE TRIM	316 SS BALL & STEM										
.25 x .375 x .25	1/4F-F03N-SE		.380	3000	1.75	1.12	3.50	1.88	0.88	2.25	1	-
.50 x .375 x .50	1/2R-F03N-SE		.380	3000	1.75	1.19	3.50	1.88	0.88	2.38	1	6
.75 x .75 x .75	3/4F-F03N-SE		.750	3000	2.62	1.81	4.87	2.56	1.31	3.62	3.2	-
1 x .75 x 1	1R-F03N-SE		.750	3000	2.62	1.88	4.87	2.56	1.31	3.75	3.3	30

# Series F Carbon Steel

- Lever Operated Ball Valve
- 3000 PSI WP
- 1/4" Through 1"
- Bolted Body Construction
- LF2 Forged Steel for Low-Temp Service to -50° F
- Forged Body and Adapter
- Rugged Bolted Construction
- NACE Standard
- Low-Torque Operation
- Multi-Seal Seats
- Maintenance Free
- Fire Safe Design



## Material Description

ITEM	PART NAME	MATERIAL (NACE)
1	Weather Guard	Polyethylene
2	Stem Nut	Carbon Steel
3	Spacer	Carbon Steel
4	Lock Plate	Carbon Steel
5	Handle	Carbon Steel
6	Stem Washer	Acetal
7	Stop Pin	Carbon Steel
8	Stem O-Ring	Fluorocarbon
9	Stem Seal	TFE
10	Stem	316 Stainless Steel
11	Body	ASTM A350 LF2
12	Seat	Nylon (TFE Optional)
13	Ball	316 Stainless Steel
14	Body Seal	Fluorocarbon
15	End Adapter	ASTM A350 LF2
16	Body Bolts	ASTM A320 L7M

\* Handle and lock device are standard.

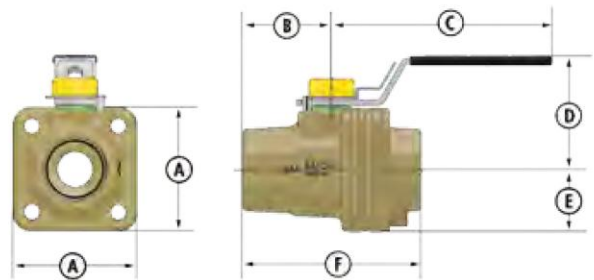
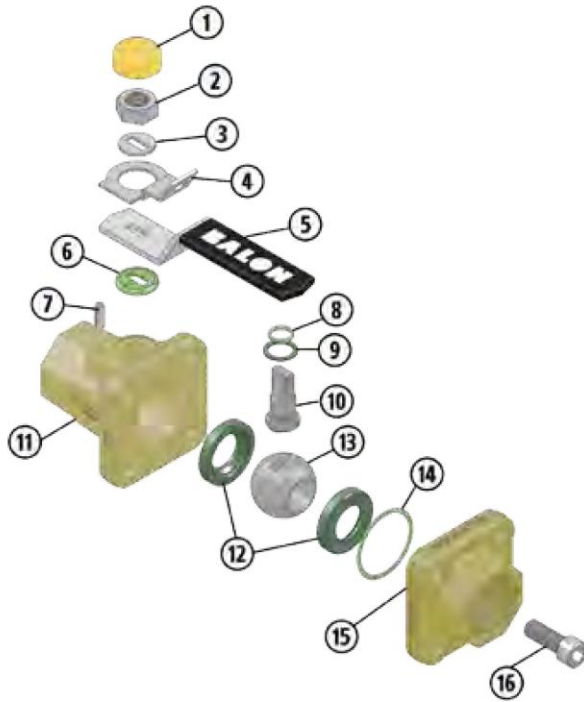

## Dimensional Data

SIZE	CATALOG NUMBER		PORT	WP	A	B	C	D	E	F	LBS.	Cv
	NACE TRIM	316 SS BALL & STEM										
.25 x .375 x .25	1/4F-F03NL-SE		.380	3000	1.75	1.12	3.50	1.88	0.88	2.25	1	-
.50 x .375 x .50	1/2R-F03NL-SE		.380	3000	1.75	1.19	3.50	1.88	0.88	2.38	1	6
.75 x .75 x .75	3/4F-F03NL-SE		.750	3000	2.62	1.81	4.87	2.56	1.31	3.62	3.2	-
1 x .75 x 1	1R-F03NL-SE		.750	3000	2.62	1.88	4.87	2.56	1.31	3.75	3.3	30

# Series F Carbon Steel

- Lever Operated Ball Valve
- To 5000 PSI WP
- 1" Through 4"
- Bolted Body Construction

- Available in LF2 Forged Steel for Low-Temp Service to -50° F
- Multi-Seal Seats
- Bolted Body Protects Against End Adapter Blowout
- Fire Safe Design
- NACE Option With 316 Stainless Steel Ball and Stem Available
- Rugged Locking Device Standard
- Maintenance Free



## Material Description

ITEM	PART NAME	MATERIAL (STANDARD)	MATERIAL (NACE)	LOW TEMP (NACE)
1	Handle*	Carbon Steel/Ductile Iron	Carbon Steel/Ductile Iron	Carbon Steel/Ductile Iron
2	Handle Bolt	Standard Hex Bolt	Standard Hex Bolt	Standard Hex Bolt
3	Weather Guard	Polyethylene	Polyethylene	Polyethylene
4	Lock Plate Retainer	Carbon Spring Steel	Carbon Spring Steel	Carbon Spring Steel
5	Lock Plate	Carbon Steel	Carbon Steel	Carbon Steel
6	Dust Cover	Polyethylene	Polyethylene	Polyethylene
7	Stop Plate Retainer	Carbon Spring Steel	Carbon Spring Steel	Carbon Spring Steel
8	Stop Plate	Carbon Steel	Carbon Steel	Carbon Steel
9	Stem O-Ring	Buna-N	Fluorocarbon	Fluorocarbon
10	Stem Seal	TFE	TFE	TFE
11	Stem	Carbon Steel	316 Stainless Steel	316 Stainless Steel
12	Ball	Carbon Steel Nickel Chrome Plated	316 Stainless Steel	316 Stainless Steel
13	Ball Seat	Nylon/Acetal (TFE Optional)	Nylon/Acetal (TFE Optional)	Nylon/Acetal (TFE Optional)
14	Body O-Ring	Buna-N	Fluorocarbon	Fluorocarbon
15	End Adapter	ASTM A105	ASTM A105	ASTM A350LF2
16	Body	ASTM A105	ASTM A105	ASTM A350LF2
17	Body Bolts	ASTM A193 B7M	ASTM A193 B7M	A320L7M

\*Handle is optional. Ball valves can also be operated with a standard open-end wrench.

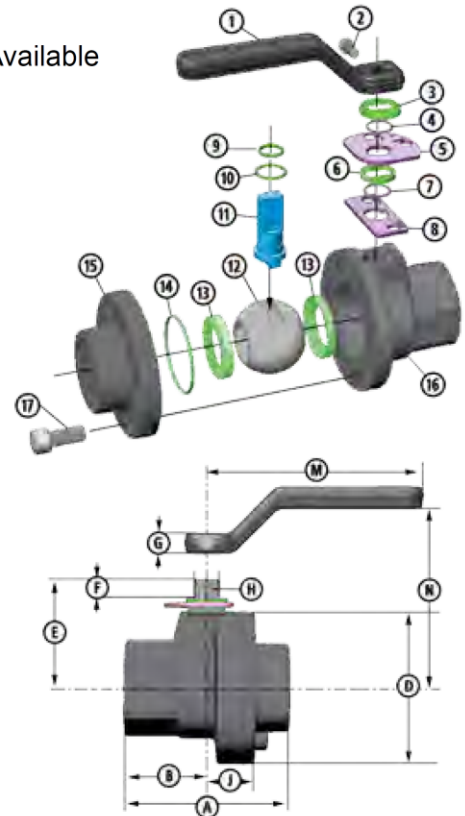

## Dimensional Data

SIZE	CATALOG NUMBER			PORT	WP	A	B	D	E	F	G	H	J	M	N	LBS.	HANDLE	Cv
	STANDARD TRIM CARBON STEEL BALL & STEM	NACE TRIM 316 SS BALL & STEM	LOW TEMP 316 SS BALL & STEM															
1x1x1	1F-F93-SE	1F-F93N-SE	N/A	1	2500	3.87	1.93	3.37	2.37	.50	.340	.685	1.12	4.37	2	4.3	P-333-CS	-
1x1x1	1F-F03-SE	1F-F03N-SE	1F-F03NL-SE	1	3000	3.87	1.93	3.37	2.37	.50	.340	.685	1.12	4.37	2	4	P-333-CS	-
1.5x1.5x1.5	1.5F-F03-SE	1.5F-F03N-SE	N/A	1.5	3000	5.25	2.62	5.12	3.62	.75	.434	.873	1.62	7.25	5.25	12.8	P-4128-CS	-
2x1.5x2	2R-F93-SE	2R-F93N-SE	N/A	1.5	2500	5.50	2.75	5.12	3.62	.75	.434	.873	1.62	7.25	5.25	13.5	P-4128-CS	125
2x1.5x2	2R-F03-SE	2R-F03N-SE	2R-F03NL-SE	1.5	3000	5.50	2.75	5.12	3.62	.75	.434	.873	1.62	7.25	5.25	13	P-4128-CS	125
2x1.5x2	2R-F5M-SE	2R-F5MN-SE	N/A	1.5	5000	6	3	6	3.62	.75	.434	.873	1.75	10.25	5.62	20	P-4125-DI	125
2x2x2	2F-F93-SE	2F-F93N-SE	N/A	2	2000	5.75	2.87	6.12	4.37	.87	.497	.998	2	10.25	6.20	20	P-4129-CS	-
2x2x2	2F-F03-SE	2F-F03N-SE	2F-F03NL-SE	2	2500	5.75	2.87	6.12	4.37	.87	.497	.998	2	10.25	6.20	20	P-4129-CS	-
3x2x3	3R-F93-SE	3R-F93N-SE	3R-F93NL-SE	2	2000	7.62	3.81	6.87	4.37	.87	.497	.998	2.06	10.25	6.20	32	P-4129-CS	180
3x3x3	3F-F63-SE	3F-F63N-SE	3F-F63NL-SE	3	1500	8.37	4.18	8	5.75	1.06	.747	1.373	2.375	20	7.75	46	P-4127-DI	-
4x3x4	4R-F63-SE	4R-F63N-SE	4R-F63NL-SE	3	1500	8.87	4.43	8	5.75	1.06	.747	1.375	2.375	20	7.75	47	P-4127-DI	500