

# 3" HYDRAULIC SUBMERSIBLE VORTEX FLOW TRASH PUMP

**MODEL S3T** (Aluminum Body)  
**MODEL S3TDI** (Ductile Iron Body)  
 3" (75 mm) Discharge

Our S3T model is designed for jobs such as construction sites and manhole pumping where lightweight, high volume, trash pumps are needed. It has the ability to pass through a 12" opening and pump in debris laden areas. A small hole strainer is available for limiting solids to be pumped.



## FEATURES

- Stainless Steel Vortex Flow Impeller
- Oil Lubricated Seals (can run dry)
- Variable Speed hydraulic drive
- Small overall size for use tight spaces
- Can be bolted directly into a pipeline
- Safe Hydraulic Drive can be used where electric power is hazardous or impractical
- Dependable gear type hydraulic motor
- Operates with our HT11 to HT15 power units or other hydraulic power sources capable of flows of 5-8 GPM

## SPECIFICATIONS

|                         |                                  |
|-------------------------|----------------------------------|
| WEIGHT S3T:             | 25 lbs. (11 kg)                  |
| S3TDI:                  | 48 lbs. (22 kg)                  |
| HEIGHT:                 | 14" (36 cm)                      |
| WIDTH (@ widest point): | 11 3/4" (30 cm)                  |
| DISCHARGE:              | 3" NPT(F)                        |
| INLET FLANGE:           | 3", 125# ASA                     |
| SOLIDS HANDLING:        | 2 1/2" (63 mm)                   |
| HOSE PORTS:             | 1/2" NPT (F)                     |
| PUMP BODY S3T:          | Aluminum                         |
| S3TDI:                  | Ductile Iron                     |
| IMPELLER:               | Stainless Steel                  |
| WEAR RING:              | Ductile Iron                     |
| SHAFT:                  | Plated 4140 Steel                |
| SHAFT SEAL:             | Carbon/Ceramic (Std)             |
| ELASTOMERS:             | Buna N (Std)                     |
| HYDRAULIC OIL:          | 214-320 s.s.u. @ 100°F (64°C)    |
| INPUT FLOW:             | Max. 8 GPM (30 LPM)              |
| OPERATING PRESSURE:     | Max. 2500 PSI (170 Bar)          |
| POWER SOURCE:           | Any Open Center Hydraulic System |

## Model S3T Overall Dimensions

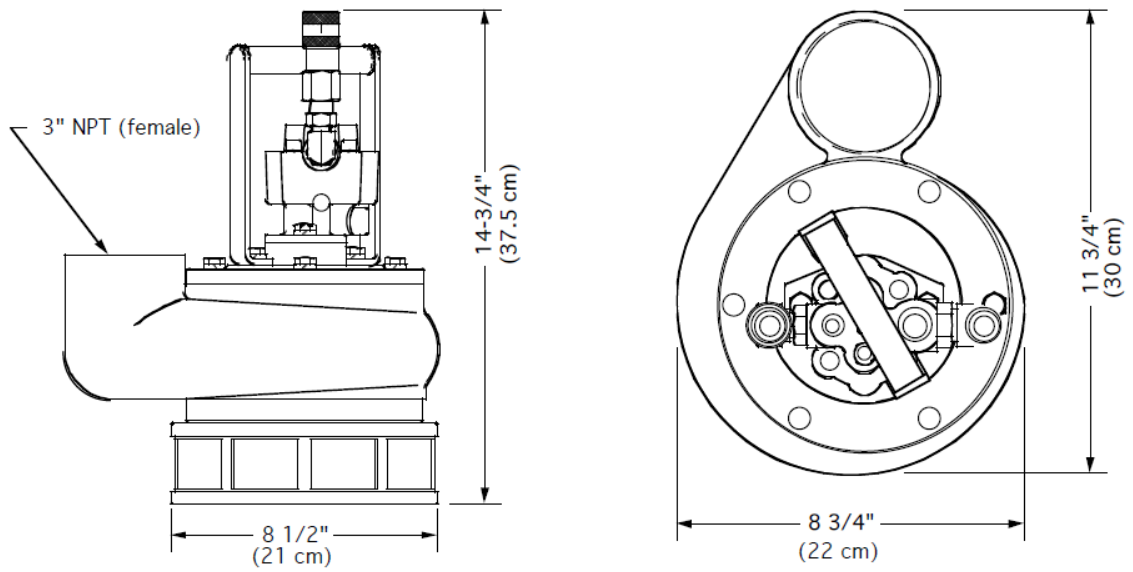

## S3T Typical Performance

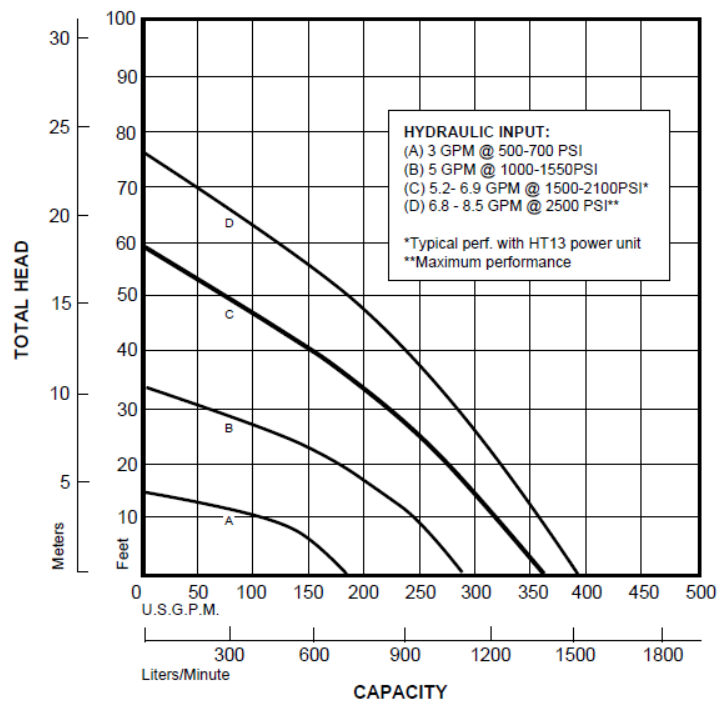

Curves are based on pumping water at 60°F. For performance curves other than shown above, consult factory.