

8" HYDRAULIC SUBMERSIBLE VORTEX FLOW TRASH PUMP

MODEL S8T

8" (200 mm) Discharge

The S8T is a vortex flow pump designed to provide reliable high volume pumping on jobs ranging from wastewater to sewage to sludge and debris laden applications. Its ability to pass large semi-solids allows more shear sensitive materials to be pumped with less degradation.



FEATURES

- Recessed Vortex Impeller (will pass 7" semi-solids)
- Compact Design allows this pump to fit through a 34" opening
- Variable Speed hydraulic drive provides a wide range of performance
- Oil Lubricated Seals (can run dry)
- High Efficiency Balanced Vane hydraulic motor
- Can be bolted directly into a pipeline or used as a booster pump
- Safe Hydraulic Drive can be used where electric power is hazardous or impractical
- Operates with our HT100 to HT150 power units or other hydraulic power sources capable of flows of 50 - 70 GPM

SPECIFICATIONS

WEIGHT:	536 lbs. (243 kg)
HEIGHT:	42" (107 cm)
WIDTH (@ widest point):	33 3/4" (86 cm)
DISCHARGE:	8" 125# ASA Flange
INLET:	8" 125# ASA Flange
SOLIDS HANDLING:	7" (17 cm)
HOSE PORTS:	1 1/4" or 1 1/2" NPT(F)
PUMP BODY:	Ductile Iron
IMPELLER:	Ductile Iron
WEAR RING and WEAR PLATE:	ASTM A36 Steel
SHAFT:	17-4 PH Stainless Steel
SHAFT SEAL:	Silicon Carbide
ELASTOMERS:	Buna N (Std)
HYDRAULIC OIL:	214-320 s.s.u. @ 100°F (64°C)
INPUT FLOW:	Max 70 GPM (265 LPM)
OPERATING PRESSURE:	Max 2800 PSI (190 Bar)
POWER SOURCE:	Any Open Center Hydraulic System

Model S8T Overall Dimensions

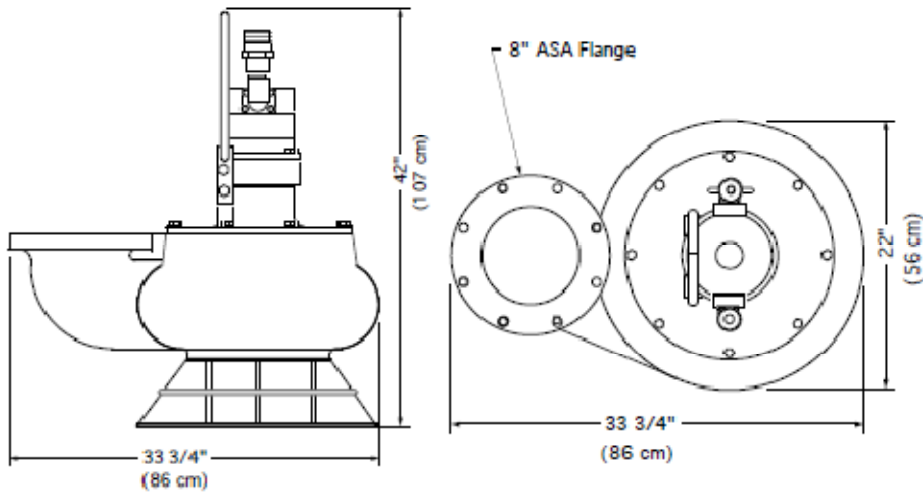

S8T Typical Performance

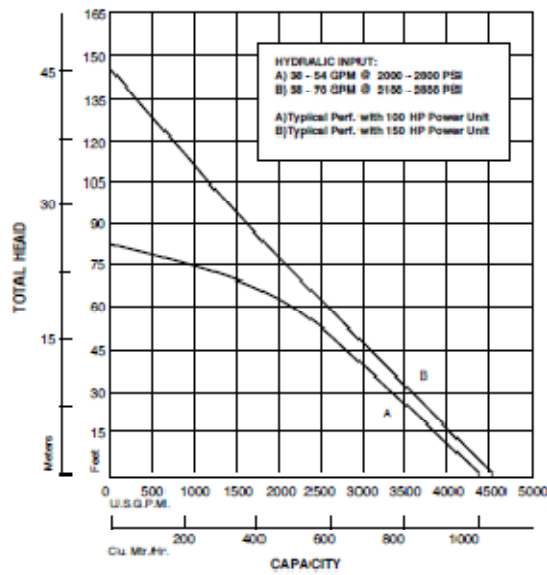

Curves are based on pumping water at 60°F. For performance curves other than shown above, consult factory.