

4" HYDRAULIC SUBMERSIBLE SHREDDER PUMP

MODEL S4SHR

4" (100 mm) Discharge

The S4SHR is designed to continuously rip and shear solids with a 360° shredding action. Great for municipal, industrial, agricultural and institutional waste applications. A guide rail assembly is available for stationary applications.



CE

FEATURES

- Open-Vane Shredder Impeller with Tungsten Carbide Cutting Tip
- Hardened Macerator Suction Plate
- Oil Lubricated Seals (can run dry)
- Variable Speed hydraulic drive
- Versions for Portable or Fixed Installations
- Safe Hydraulic Drive can be used where electric power is hazardous or impractical
- Dependable gear type hydraulic motor
- Operates with our HT15 to HT25 power units or other hydraulic power sources capable of flows of 10 - 15 GPM

SPECIFICATIONS

WEIGHT:	254 lbs. (115 kg)
HEIGHT:	28" (71 cm)
WIDTH (w/Discharge elbow):	29 1/2" (75 cm)
(Across Volute):	16 3/4" (43 cm)
DISCHARGE:	4" ANSI Flange or 4" NPT(F)
SOLIDS HANDLING:	3 1/2" (89 mm)
HOSE PORTS:	3/4" (-12) SAE(F)
PUMP BODY:	Ductile Iron
IMPELLER:	Ductile Iron
SHREDDER BLADE:	Tungsten Carbide
SHAFT:	Stainless Steel
SHAFT SEAL:	(Upper) Carbon/Ceramic (Lower) Silicon Carbide
ELASTOMERS:	Buna N
HYDRAULIC OIL:	214-320 s.s.u. @ 100°F (64°C)
INPUT FLOW:	Max. 15 GPM (57 LPM)
OPERATING PRESSURE:	Max. 2600 PSI (177 Bar)
POWER SOURCE:	Any Open Center Hydraulic System

Model S4SHR Overall Dimensions

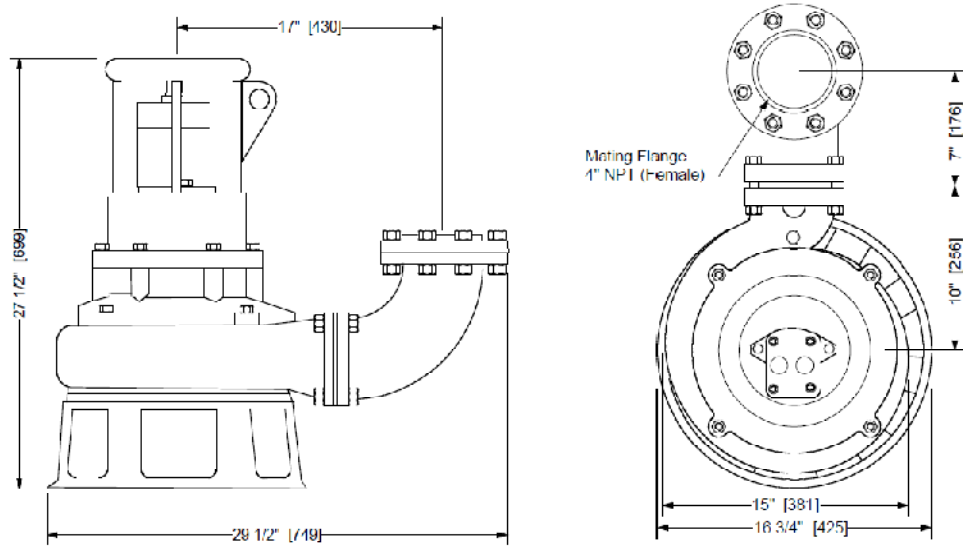

S4SHR Typical Performance

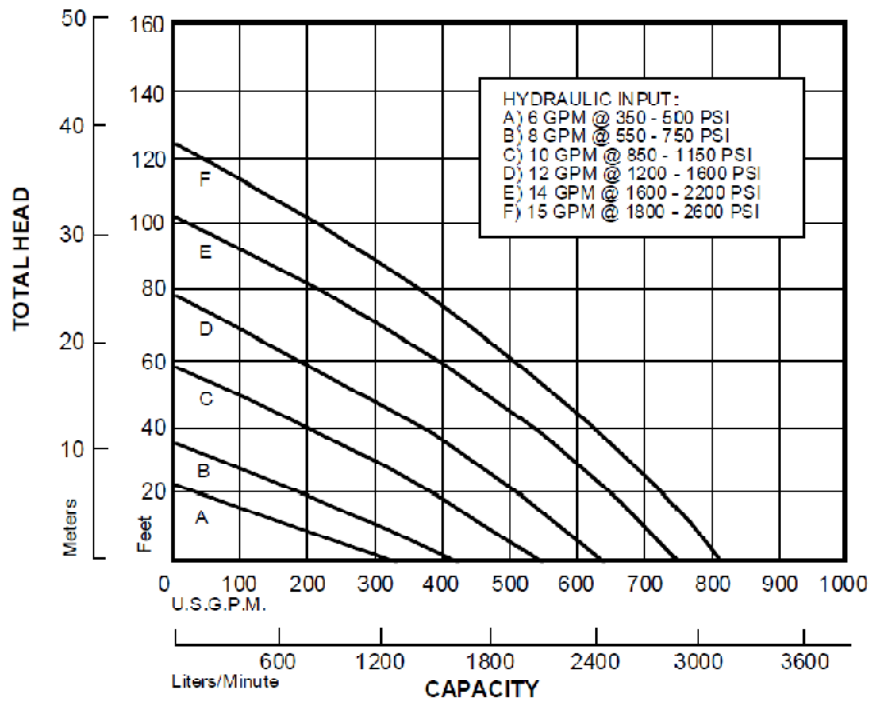

Curves are based on pumping water at 60°F. For performance curves other than shown above, consult factory.