

4" HYDRAULIC SUBMERSIBLE SAND / SLURRY PUMP with AGITATOR

MODEL S4CSL

4" (100 mm) Discharge

The S4CSL pump is designed to use in applications requiring settled solids to be put into suspension and pumped with the discharge water. Primary applications include de-silting ponds, lakes and streams. Other jobs may include filling sand bags to prevent beach erosion, tank and digester cleaning or pumping sediment from caissons.



FEATURES

- Hardened Alloy Wear Parts
- Built-in Agitator for stirring up solids
- Oil Lubricated Seals (can run dry)
- Variable Speed hydraulic drive
- Small Size allows pump to fit through a 17 inch opening
- Safe Hydraulic Drive can be used where electric power is hazardous or impractical
- Dependable gear type hydraulic motor
- Operates with our HT20 to HT35 power units or other hydraulic power sources capable of flows to 17 GPM

SPECIFICATIONS

WEIGHT:..... 273 lbs. (124 kg)
HEIGHT:..... 31" (79 cm)
WIDTH (@ widest point):.....16 1/4" (41 cm)
DISCHARGE:..... 4" NPT
SOLIDS HANDLING:..... 1 1/2" (38 mm)
HOSE PORTS:..... 1/2" and 3/4" NPT (F)
VOLUTE*:..... Hardened Ductile Iron
IMPELLER:..... High Chrome Alloy
WEAR PLATE..... High Chrome Alloy
AGITATOR:..... High Chrome Alloy
SHAFT:..... 304 Stainless Steel
SHAFT SEALS: (upper)..... Carbon/Ceramic
(Lower)..... Silicon Carbide
HYDRAULIC OIL:..... 214-320 s.s.u. @ 100°F (64°C)
INPUT FLOW:..... Max 17 GPM (64 LPM)
OPERATING PRESSURE:.... Max 2800 PSI (190 Bar)
POWER SOURCE:.. Any Open Center Hydraulic System

* Optional NI-Hard volute available for highly abrasive applications

Model S4CSL Overall Dimensions

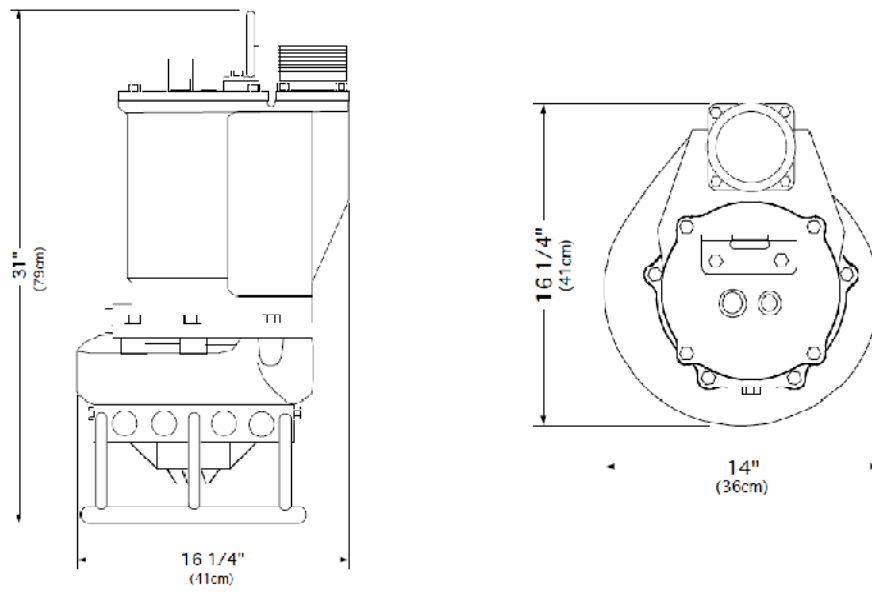

S4CSL Typical Performance

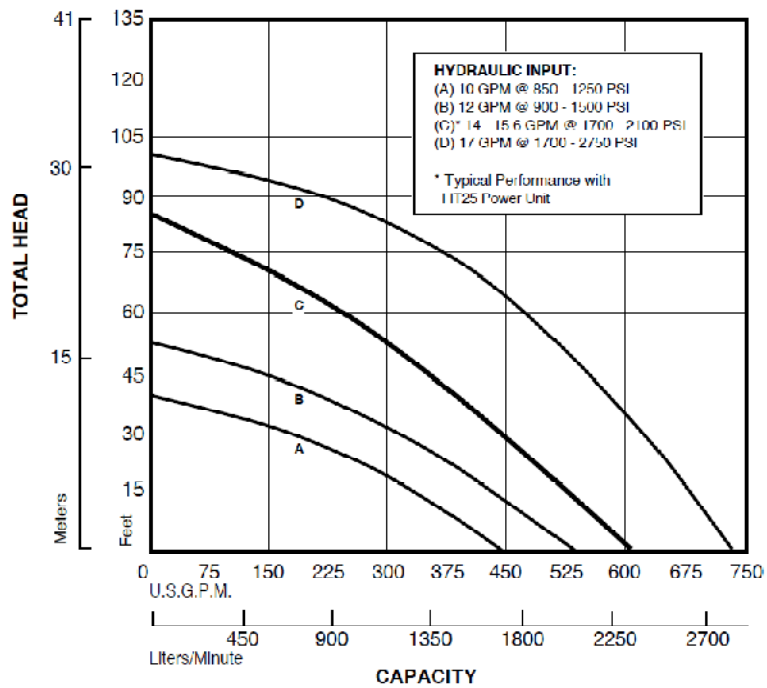

Curves are based on pumping water at 60°F. For performance curves other than shown above, consult factory.